

Stationary concrete pump

BSA 1408 E

Output up to 77 m³/h
 Delivery pressure up to 109 bar

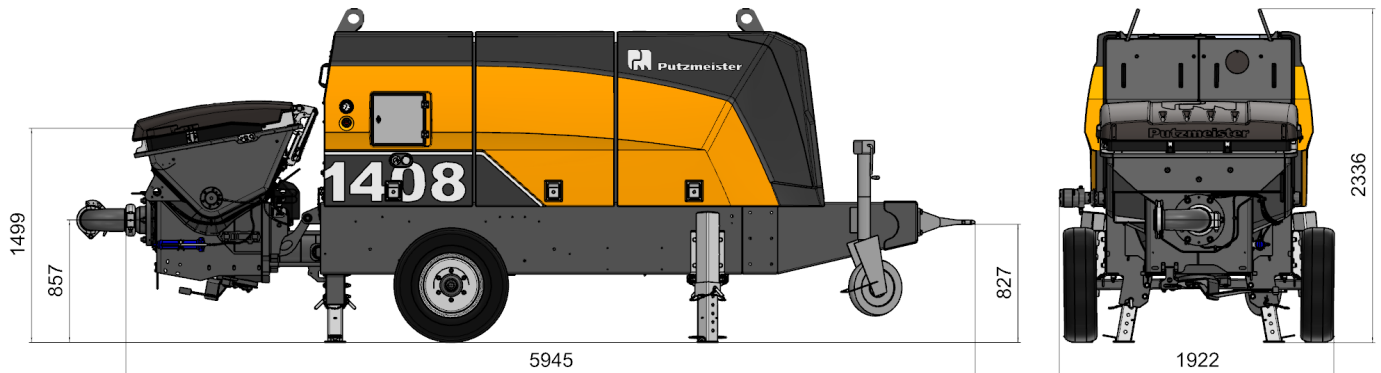

Note: Standard version. Dimensions and weights depend on equipment. Subject to technical modifications and errors.

Technical data

Model		BSA 1408 E
Material number		103419.000
Output	m ³ /h	77 / 52 *
Delivery pressure	bar	73 / 109 *
Delivery cylinder	Ø mm	200
Delivery cylinder stroke	mm	1400
Strokes / minute		29 / 20 *
Engine power	kW	110
Hopper		RS 909
Capacity	l	approx. 600
Filling height	m	1.49
Transfer tube		S 2015 D
Line connection	mm	SK 125
Pressure connection	"	5.5
Control system		Ergonic 3 FFH
Weight approx.	kg	5900

* Values for hydraulic fluid being fed to piston-side
 All data maximum theoretical

Serial equipment

Agitator safety switch off	Ergonic Graphic Display (EGD)
Cable remote control 10 m	Flushing water pump 50 l/min 20 bar
Central lubrication on hopper with grease gun	Gate valve connection
Cleaning accessories	Grill 60 mm
Coloring: Pump, frame, roof, tank and hood anthracite-grey Cover chrome yellow	Operating manuals and spare part list
Concrete hopper with agitator	Pump flow meter
Concrete output adjust	Reduction elbow 90° SK 150 → SK 125
Concrete pressure adjust	Splash guard foldable
Drive electric 110 kW	Tool set incl. standard equipment
Electronic error management	Trailer F8, can be driven on site

See quotation for exact serial delivery scope.
 Comprehensive range of options available on request.